

SNAP Power Supplies

Features

- Built-in fuse, ON/OFF power switch, and LED indicator
- Convenient panel mounting; optional DIN-rail mounting
- Easy connections
- Wide input voltage range
- Factory Mutual approved (except SNAP-PS5U)

Description

SNAP power supplies provide the best source of AC or DC power for your Opto 22 SNAP PAC hardware. Packaged in a compact and sturdy housing, SNAP power supplies include a built-in fuse, an LED status indicator, and an ON/OFF power switch for ease of use.

The **SNAP-PS24** and **SNAP-PS24U** power supplies are designed for either of two purposes:

- to provide primary power for a SNAP PAC S-series controller
- to provide 24 volts of DC loop power for SNAP analog modules mounted on a SNAP PAC rack

The **SNAP-PS5**, **SNAP-PS5-24DC**, and **SNAP-PS5U** power supplies are designed to provide 5 VDC power for a SNAP PAC rack with an I/O processor (SNAP PAC brain or R-series controller) and I/O modules mounted on the rack. The combination of a rack, processor, and modules is called an *I/O unit*.

Opto 22 recommends using one SNAP power supply for each I/O unit and each controller. Choose the power supply based on the load required for the I/O unit. See the power requirements tables starting on [page 11](#) for help in determining the power supplies you need. Additional information on using power supplies can be found in the Opto 22 technical note *Using Power Supplies with Opto 22 Systems* (form #1271, available on our website, www.opto22.com).

All SNAP power supplies except the SNAP-PS5-24DC require AC input power. The SNAP-PS5U and SNAP-PS24U accommodate a wide range of AC input voltages, from 100 to 250 VAC.

The SNAP-PS5-24DC DC-to-DC power supply requires a 24 VDC input and is ideal for systems using DC backup power.

Each SNAP power supply can be mounted in one of two ways: next to the controller or SNAP I/O unit it powers, using the standard panel-mounting base, or directly on a DIN rail using the optional DIN-rail adapter.



SNAP Power Supplies

AC or DC input power connections, as required by the model, are made to a removable terminal strip on top of the power supply. DC output power is then ready to be hooked up to the controller or rack using the attached wiring harness.

Notes for legacy hardware: SNAP power supplies are also compatible with Ethernet-based SNAP Ultimate, SNAP Ethernet, and SNAP Simple I/O, and with serial-based SNAP I/O units such as those with a B3000, SNAP-HA, or SNAP-B3000-MODBUS brain.

Part Numbers

Part	Description
SNAP-PS5	SNAP Power Supply 120 VAC input; 5 VDC, 4 A output
SNAP-PS5-24DC	SNAP Power Supply 24 VDC input; 5 VDC, 4 A output
SNAP-PS5U	SNAP Power Supply 100–250 VAC input; 5 VDC, 5 A output
SNAP-PS24	SNAP Power Supply 120 VAC input; 24 VDC, 3/4 A output
SNAP-PS24U	SNAP Power Supply, 100–250 VAC input; 24 VDC, 1-1/4 A output
SNAP-PSDIN	DIN-Rail Adapter for SNAP-PS5, SNAP-PS24, or SNAP-PS5-24DC
SNAP-PSUDIN	DIN-Rail Adapter for SNAP-PS5U or SNAP-PS24U

Specifications

	SNAP-PS5	SNAP-PS5-24DC	SNAP-PS5U
Input Voltage	95–130 VAC, 47–63 Hz	18–32 VDC	100–250 VAC, 47–63 Hz
Output Voltage	5.1 ±0.1 VDC	5.1 ±0.1 VDC	5.1 ±0.1 VDC
Output Current	4.0 A	4.0 A	5.0 A
Dimensions	See dimensional drawings starting on page 7 .	See dimensional drawings starting on page 7 .	See dimensional drawings on page 9 .
Weight	15 oz. (425.25 g)	15 oz. (425.25 g)	1.9 lbs (863.63 g)
Operating Temperature	0° to 70° C	0° to 70° C	0° to 70° C
Storage Temperature	-30° to 85° C	-30° to 85° C	-30° to 85° C
Fuse	Opto 22 PN: SNAP-FUSE1AB Vendor PN: GDC-1A (Bussman)	Opto 22 PN: SNAP-FUSE2AB Vendor PN: GDB-2A (Bussman)	Internal fuse

	SNAP-PS24	SNAP-PS24U
Input Voltage	95–130 VAC, 47–63 Hz	100–250 VAC, 47–63 Hz
Output Voltage	24 ± 0.6 VDC	24 ± 0.1 VDC
Output Current	0.75 A	1.25 A
Dimensions	See dimensional drawings starting on page 7 .	See dimensional drawings on page 9 .
Weight	2.1 lbs (952.54 g)	1.9 lbs (863.63 g)
Operating Temperature	0° C to 70° C	0° C to 70° C
Storage Temperature	-30° C to 85° C	-30° C to 85° C
Fuse	Opto 22 PN: SNAP-FUSE1AB Vendor PN: GDC-1A (Bussman)	Internal fuse

I/O Unit Power Requirements

The tables starting on [page 11](#) will help you determine the power supply needs for your system. Copy the power requirements worksheet and complete one for each distributed I/O unit.

In addition, keep the following power recommendations in mind. For more help with power supplies, see Opto 22 form #1271, *Using Power Supplies with Opto 22 Systems*.

Use a single power supply per rack

In general, we recommend you use an independent, isolated, regulated power supply locally with each rack. Local isolated supplies offer these advantages:

- Short supply conductors, which minimize losses
- Power redundancy, so the failure of a single supply causes only a single rack failure, not a total system failure
- Fewer voltage drops and ground loops (Voltage drops and subsequent ground loops may occur when power is distributed over a large system.)

Always use a separate field supply

Use a separate power supply for the field side of the I/O. Using the rack supply for field actuation and monitoring defeats the isolation the I/O module offers and therefore increases the chance of a ground loop within the control system. Additionally, a sudden change of current on the field side can cause undesirable voltage fluctuations that may interfere with the controller or I/O unit's operation.

Power wiring guidelines

- Use one power supply per I/O unit.
- Use one power supply per controller.
- Use 14 AWG wire.
- SNAP power supplies have wires of limited length to minimize voltage drop. Do not extend the length of the wires.
- If you power multiple I/O units or controllers from one power supply, use a star wiring topology. Do not daisy-chain power wiring from one device to the next.

SNAP Power Supplies

Installation

Panel Mounting (standard)

Mount the SNAP power supply in a location where the attached red and black power wires will reach the "+" and "-" power terminals on the SNAP mounting rack or controller. Do not extend the wires.

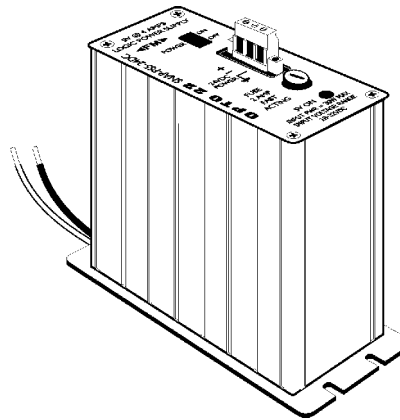

DIN-Rail Mounting (optional)

1. For DIN-rail mounting, remove the four screws that fasten the panel mounting base plate to the power supply. **Keep screws in a safe place.**
2. Remove panel mounting base plate.
3. In place of the panel mounting base plate, use the four screws removed in step 1 to fasten the DIN-rail adapter (purchased separately) to the power supply.
4. Mount the SNAP power supply on the DIN rail (next to the power connector on the I/O unit).

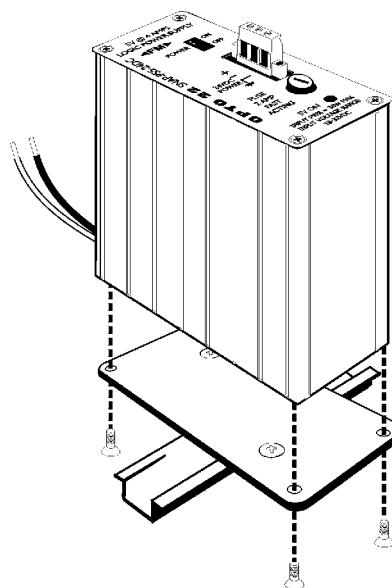
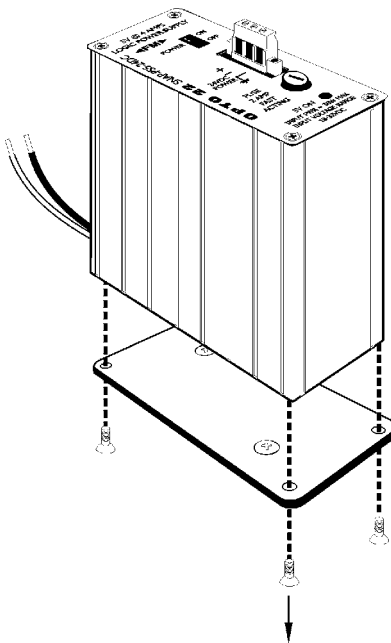

Wiring—Primary Power Supply

Wiring to a Standalone Controller

1. For a controller, check the controller's specifications in its data sheet or user's guide to make sure you have the correct power supply for the controller's requirements.
2. Follow directions in the controller's user's guide to wire the power supply to the controller. The power supply's red (or white-and-red) wire is the positive wire; the black (or white-and-black) wire is the negative wire.

Wiring to a SNAP I/O Unit

1. Using the power terminals on the SNAP mounting rack, attach the red wire to the "+" terminal and the black wire to the "-" terminal.

2. **For the SNAP-PS5 (not illustrated):** Using the removable input power connector on top of the power supply, apply 120 volts AC power between the two terminals marked "AC." The ground terminal should be connected to ground.
3. **For the SNAP-PS5-24DC (not illustrated):** Using the removable input power connector on top of the power supply, apply 24 volts DC power between the two terminals marked "±DC." The ground terminal should be connected to ground.
4. **For the SNAP-PS5U (illustrated below):** Using the removable input power connector on top of the power supply, apply 100–250 volts AC power between the two terminals marked "AC." The ground terminal should be connected to ground.

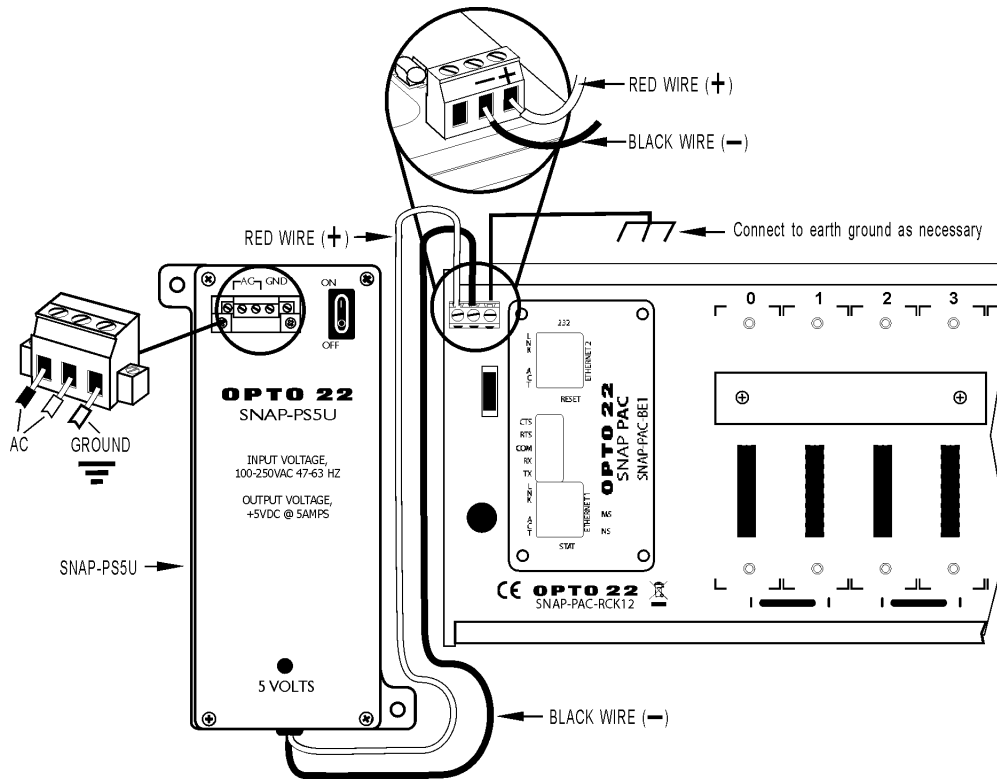

SNAP Power Supplies

Wiring—Loop Power Supply

1. Mount the SNAP-PS24 or SNAP-PS24U power supply in a location where the attached output power wires will reach the field connector for SNAP analog modules or the terminal strip on SNAP mounting racks that have the additional field wiring terminal strips.
2. The white-and-red wire is the positive wire (24 VDC). The white-and-black wire is the negative wire (24 VDC return). For specific loop power wiring information, see Opto 22 form #0784 for SNAP racks that have the additional field wiring terminal strip (see Figure 1 example below), or refer to forms #1065 and #1066 if wiring directly to the field connectors on SNAP analog modules (see Figure 2). See the next page for similar SNAP-PS24U wiring diagrams.
3. Using the removable input power connector on top of the power supply, apply 120 volts of AC power between the two terminals marked "AC." The ground terminal should be connected to ground.

Figure 1. SNAP-PS24 Used as a Loop Supply with the SNAP PAC System

This diagram shows the SNAP-PS24 used as the loop supply and a SNAP-PS5 used as the primary power supply.

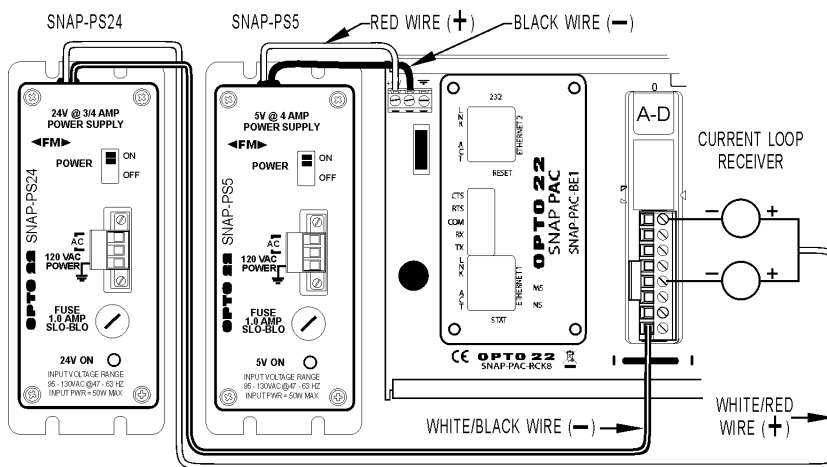
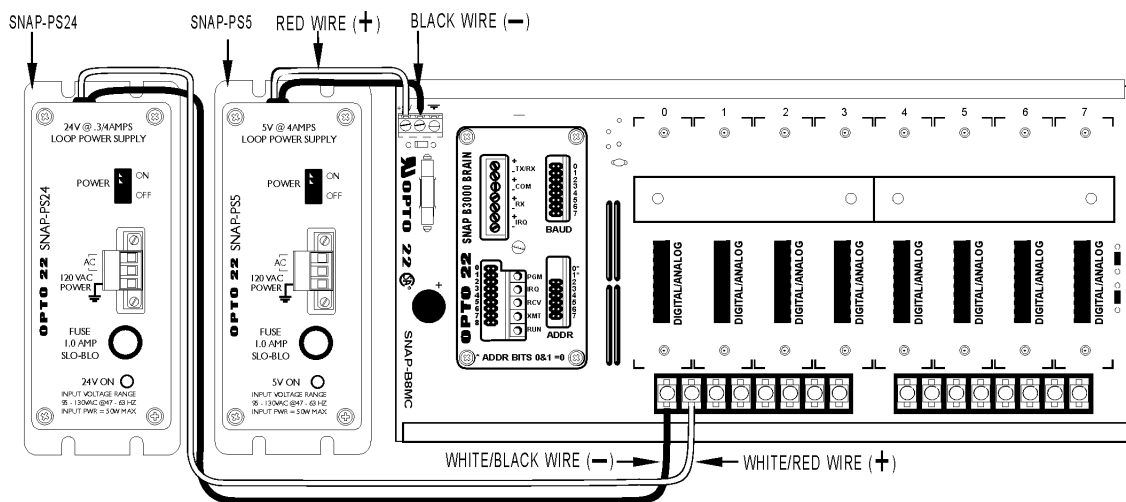

Figure 2. SNAP-PS24 Used as a Loop Supply with Legacy Hardware

The SNAP-PS24 is used as the loop supply; a SNAP-PS5 is used as the primary power supply.



Wiring—Loop Supply (continued)

Figure 1. SNAP-PS24U Used as a Loop Supply with the SNAP PAC System

This diagram shows the SNAP-PS24U used as the loop supply and a SNAP-PS5U used as the primary power supply.

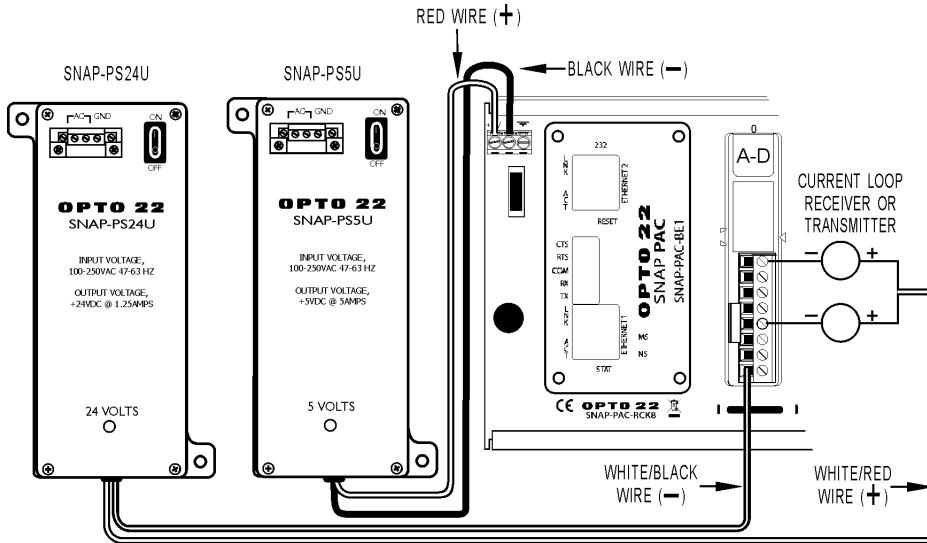
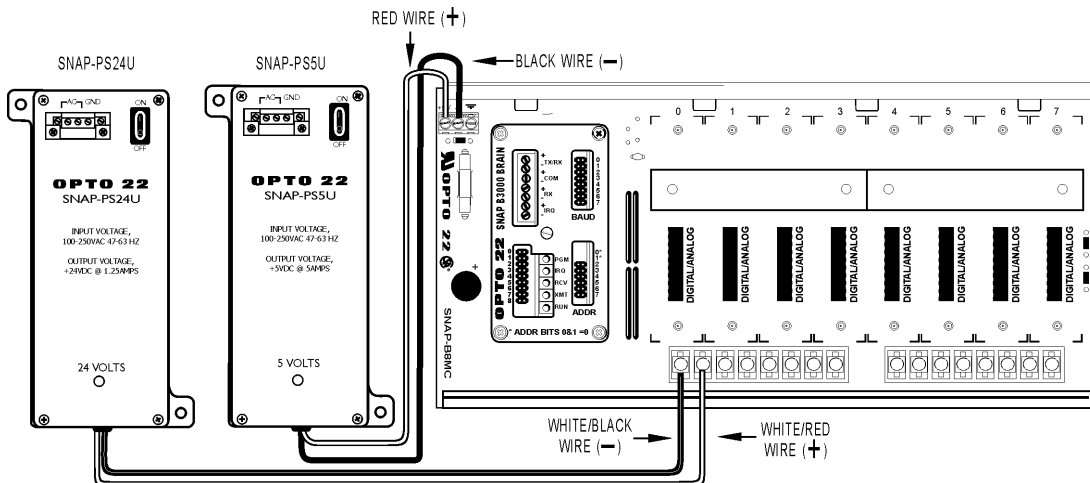

Figure 2. SNAP-PS24U Used as a Loop Supply with Legacy Hardware

The SNAP-PS24U is used as the loop supply; a SNAP-PS5U is used as the primary power supply.



SNAP Power Supplies

Dimensions—SNAP-PS5, SNAP-PS24, and SNAP-PS5-24DC

Panel Mount

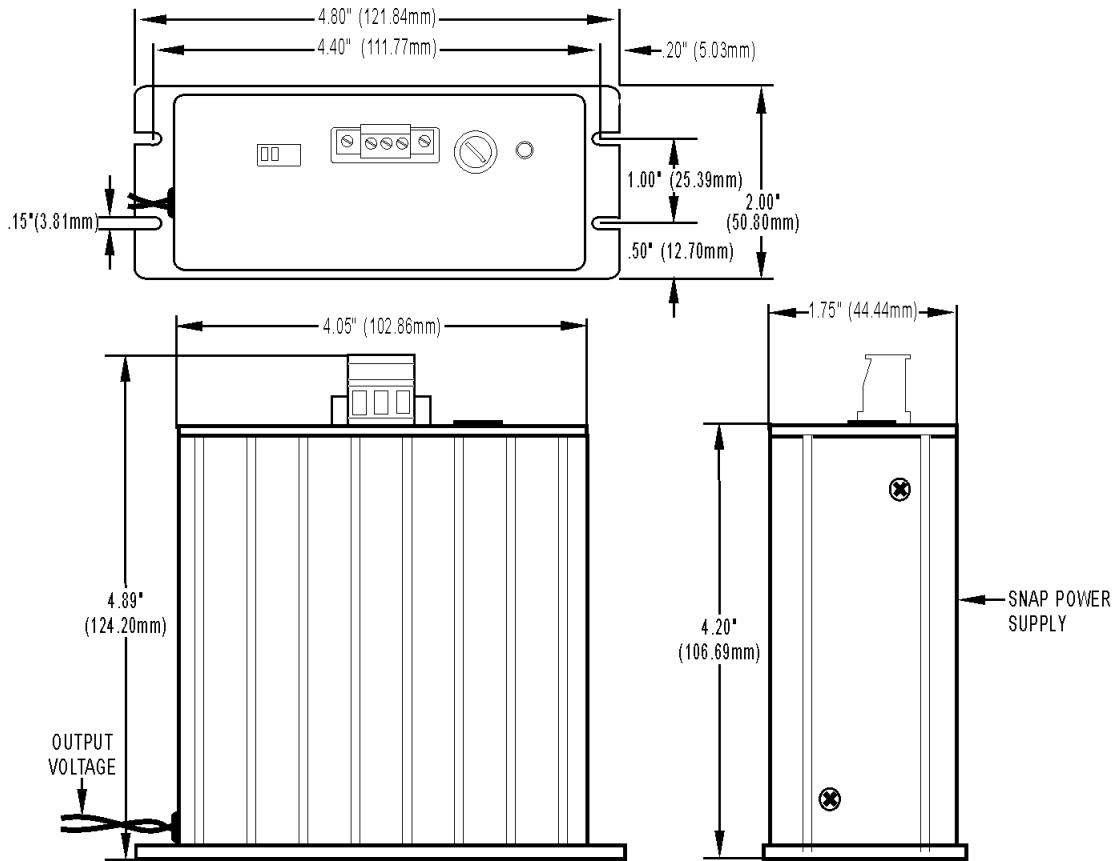

SNAP Power Supplies

Dimensions—SNAP-PS5, SNAP-PS24, and SNAP-PS5-24DC

With DIN-Rail Adapter

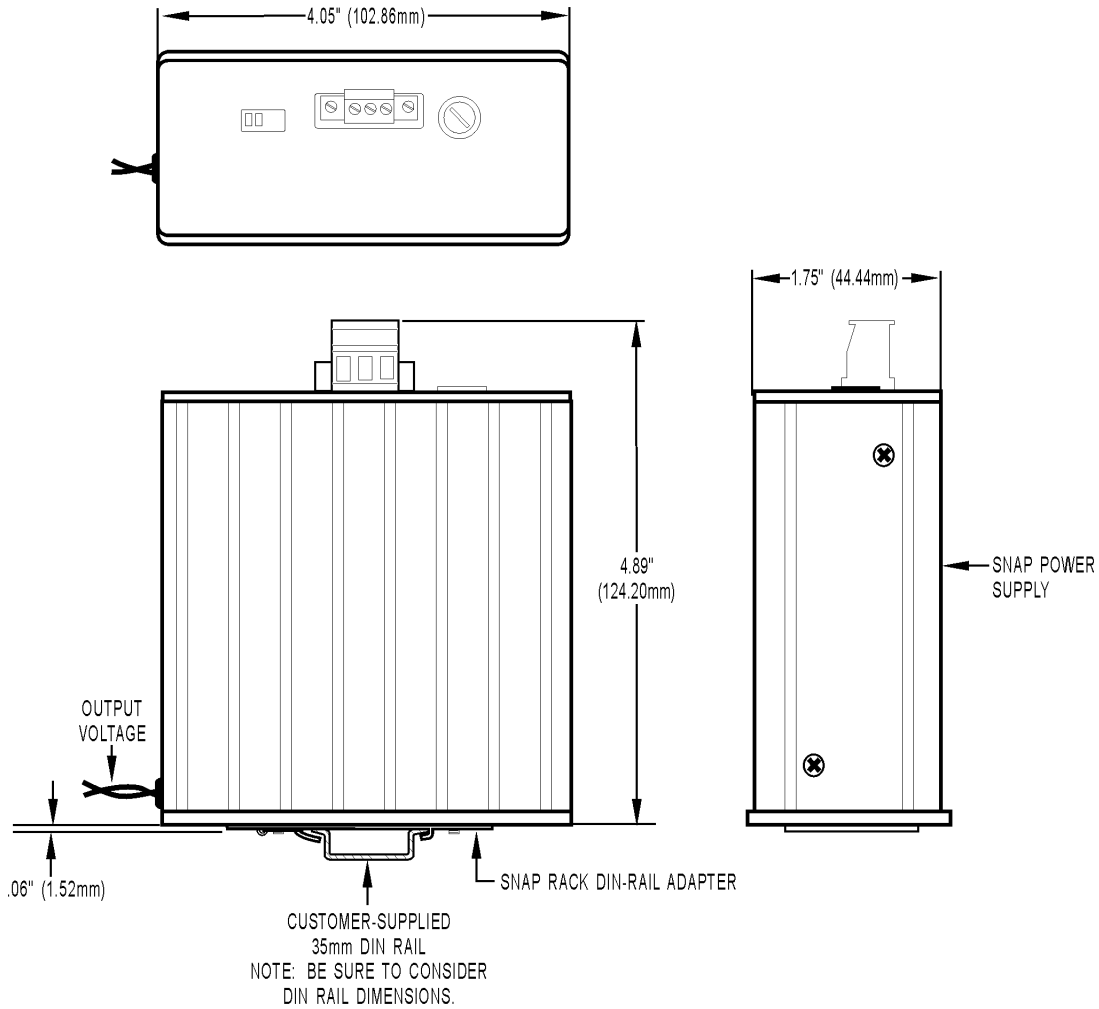

SNAP Power Supplies

Dimensions—SNAP-PS5U and SNAP-PS24U

Panel Mount

SNAP-PS5U is shown; SNAP-PS24U has the same dimensions.

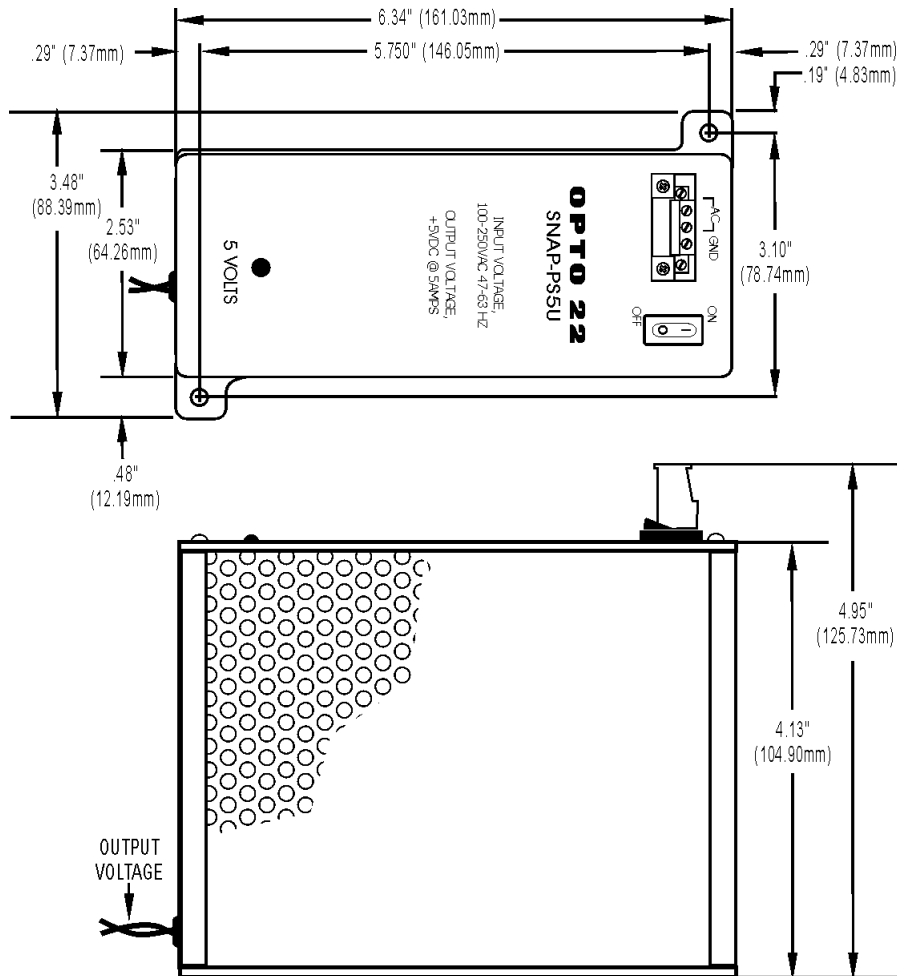

Dimensions—SNAP-PSDIN

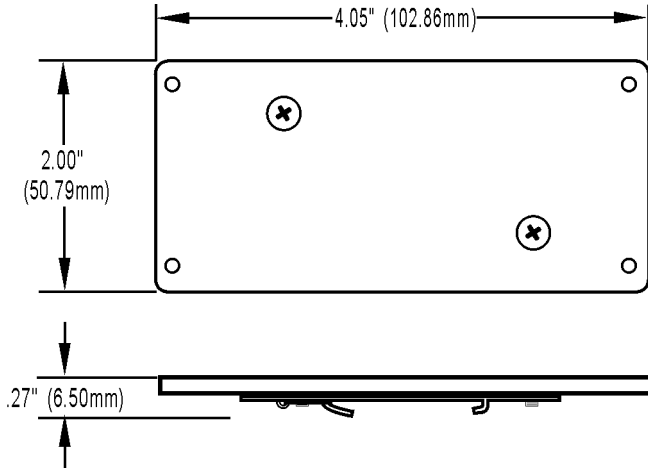

Dimensions—SNAP-PSUDIN

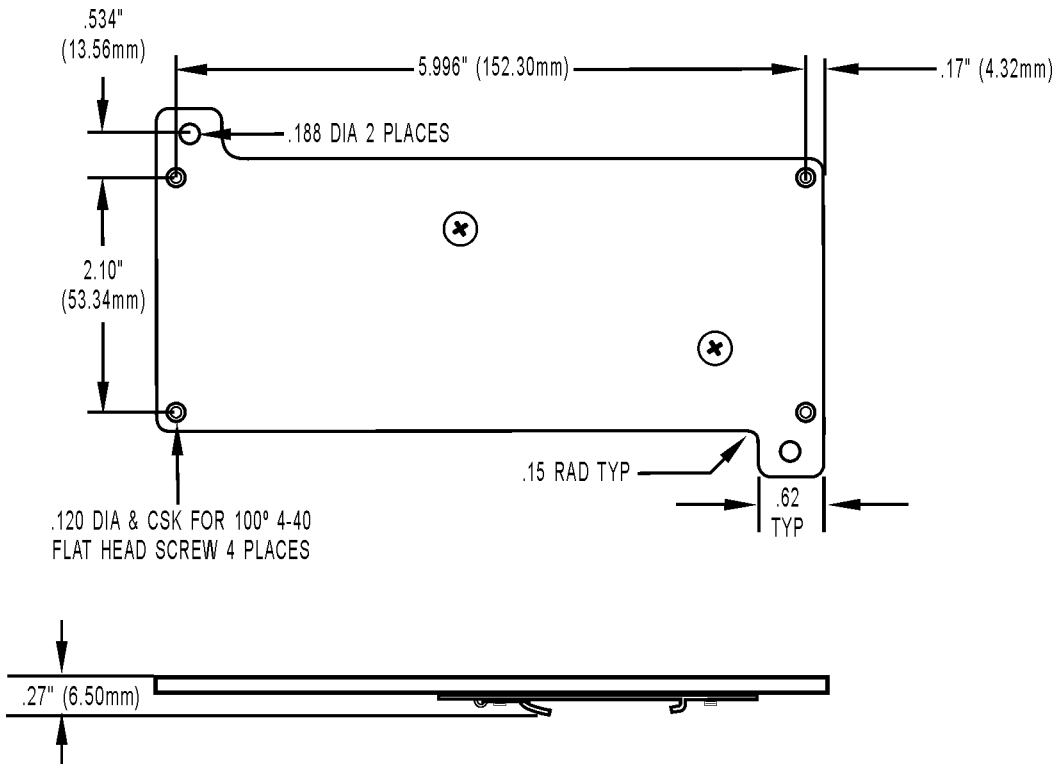

SNAP Power Supplies

Power Requirements Tables

Opto 22 recommends using one power supply per I/O unit and one power supply per controller. See "I/O Unit Power Requirements" on page 2 for additional information.

To determine power requirements for products not listed in these tables, see the data sheets for the individual products.

Controller Power Requirements

	Standalone Controller or adapter card	Power Req (VDC)	Power Req. (Amps)
	SNAP PAC S-series controllers	8–32 VDC*	10 VA**
Legacy hardware	SNAP-LCSX or -LCSX-PLUS controller	5 VDC	0.500
	SNAP-LCM4 controller	5 VDC	1.000
	M4-SENET-100 adapter card	5 VDC	1.000
	M4SARC adapter card	5 VDC	0.200
	M4DUALARC adapter card	5 VDC	0.150
	M4SARCF adapter card	5 VDC	0.250
	M4SARCFR adapter card	5 VDC	0.350

* SNAP-PAC-S1 controllers with serial numbers below 500,000 use 8–24 VDC.

** Uses 1 A if powered at 10V. To determine amps required, divide 10 by the number of volts applied. Example: $10 / 24 \text{ V} = 0.417 \text{ A}$ (24 VDC input requires 0.417 A)

I/O Processor (Brain or On-the-Rack Controller) Power Requirements

	Processor (Brain or Rack-mounted Controller)	Power Req. (Amps)*
	SNAP PAC R-series controllers (all models)	1.200
	SNAP PAC EB and SB brains (all models)	0.750
Legacy hardware	SNAP Ultimate controller/brains (all models)	1.000
	SNAP Ethernet brains	0.800
	SNAP Simple I/O brains	0.500
	B3000 (serial SNAP brain) SNAP-D64RS	0.500
	SNAP-B3000-Modbus SNAP ARCNET brains	1.000
	SNAP-B4 SNAP-B6	1.000 1.500 if terminated

*Current from 5-volt supply

(Continued on following page)

Power Requirements Tables (continued)

I/O Unit (Processor, Rack, I/O Modules) Power Requirements Worksheet

Item	Quantity	X Power Req. (Amps)	Total Power Required (Amps) ¹
SNAP processor (Enter Amps from Processor Power Requirements table)	1		
SNAP-IDC5-SW digital input module SNAP-IDC5-SW-NC digital input module SNAP-AITM-8 analog input module ² Isolated analog input and output modules (part numbers ending in -i or iSRC)		0.200	
All other 4-channel digital input and output modules (<i>not</i> high-density digital modules)		0.050	
SNAP-AICTD analog input module SNAP-AICTD-4 ³ analog input module High-density digital input and output modules ⁴ SNAP-AIMA-32, SNAP-AIV-32 analog input modules ⁴ All analog output modules except SNAP-AOA-iSRC		0.150	
SNAP-AIARMS analog input module SNAP-AIVRMS analog input module SNAP-AICTD-8 analog input module SNAP-AIMA, AIMA-4 ³ , and AIMA-8 ³ analog input modules SNAP-AITM and AITM-2 analog input modules SNAP-AIMV-4 ³ and AIMV2-4 ³ analog input modules SNAP-AIV, AIV-4 ³ , and AIV-8 ³ analog input modules		0.170	
SNAP-AIRTD analog input module SNAP-AIR40K-4 ³ analog input module SNAP-AIRATE analog input module		0.190	
SNAP-AIPM power monitoring module ³		0.100	
SNAP-AILC and AILC-2 load cell modules ³		0.120	
Serial communication and Profibus modules ³ Motion control module <i>not</i> powering a breakout board ²		0.250	
Motion control module powering a breakout board ²		0.700	
Total			

1 Current from 5-volt supply

2 Can be used with SNAP PAC R-series controllers and SNAP PAC brains, SNAP Simple, and SNAP Ultimate

3 Can be used with SNAP PAC R-series controllers and SNAP PAC brains, SNAP Simple, SNAP Ethernet, and SNAP Ultimate

4 Can be used with SNAP PAC systems only

IMPORTANT NOTE: For a SNAP-PS5 or a SNAP-PS5-24DC power supply, the total power required must not exceed 4 Amps. For a SNAP-PS5U, the total power required must not exceed 5 Amps.

To determine power requirements for products not listed in this table, see the data sheets for the individual products.

More About Opto 22

Products

Opto 22 develops and manufactures reliable, flexible, easy-to-use hardware and software products for industrial automation, remote monitoring, and data acquisition applications.

SNAP PAC System

Designed to simplify the typically complex process of understanding, selecting, buying, and applying an automation system, the SNAP PAC System consists of four integrated components:

- SNAP PAC controllers
- PAC Project™ Software Suite
- SNAP PAC brains
- SNAP I/O™

SNAP PAC Controllers

Programmable automation controllers (PACs) are multifunctional, multidomain, modular controllers based on open standards and providing an integrated development environment.

Opto 22 has been manufacturing PACs for many years. The latest models include the standalone SNAP PAC S-series and the rack-mounted SNAP PAC R-series. Both handle a wide range of digital, analog, and serial functions and are equally suited to data collection, remote monitoring, process control, and discrete and hybrid manufacturing.

SNAP PACs are based on open Ethernet and Internet Protocol (IP) standards, so you can build or extend a system without the expense and limitations of proprietary networks and protocols.

PAC Project Software Suite

Opto 22's PAC Project Software Suite provides full-featured and cost-effective control programming, HMI (human machine interface) development and runtime, OPC server, and database connectivity software to power your SNAP PAC System.

These fully integrated software applications share a single tagname database, so the data points you configure in PAC Control™ are immediately available for use in PAC Display™, OptoOPCServer™, and OptoDataLink™. Commands are in plain English; variables and I/O point names are fully descriptive.

PAC Project Basic offers control and HMI tools and is free for download on our website, www.opto22.com. PAC Project Professional, available for separate purchase, adds OptoOPCServer, OptoDataLink, options for Ethernet link redundancy or segmented networking, and support for legacy Opto 22 serial *mistic*™ I/O units.

SNAP PAC Brains

While SNAP PAC controllers provide central control and data distribution, SNAP PAC brains provide distributed intelligence for I/O processing and communications. Brains offer analog, digital, and serial functions, including thermocouple linearization; PID loop control; and optional high-speed digital counting (up to 20 kHz), quadrature counting, TPO, and pulse generation and measurement.

SNAP I/O

I/O provides the local connection to sensors and equipment. Opto 22 SNAP I/O offers 1 to 32 points of reliable I/O per module, depending on the type of module and your needs. Analog, digital, serial, and special-purpose modules are all mixed on the same mounting rack and controlled by the same processor (SNAP PAC brain or rack-mounted controller).

Quality

Founded in 1974 and with over 85 million devices sold, Opto 22 has established a worldwide reputation for high-quality products. All are made in the U.S.A. at our manufacturing facility in Temecula, California. Because we do no statistical testing and each part is tested twice before leaving our factory, we can guarantee most solid-state relays and optically isolated I/O modules for life.

Free Product Support

Opto 22's Product Support Group offers free, comprehensive technical support for Opto 22 products. Our staff of support engineers represents decades of training and experience. Product support is available in English and Spanish, by phone or email, Monday through Friday, 7 a.m. to 5 p.m. PST.

Free Customer Training

Hands-on training classes for the SNAP PAC System are offered at our headquarters in Temecula, California. Each student has his or her own learning station; classes are limited to nine students. Registration for the free training class is on a first-come, first-served basis. See our website, www.opto22.com, for more information or email training@opto22.com.

Purchasing Opto 22 Products

Opto 22 products are sold directly and through a worldwide network of distributors, partners, and system integrators. For more information, contact Opto 22 headquarters at 800-321-6786 or 951-695-3000, or visit our website at www.opto22.com.

www.opto22.com